

# AKG.EMOTION

EMOTION  
MICROPHONE  
SERIES

[www.akg.com](http://www.akg.com)

ARTIST SAVAGE GARDEN



new!

## Deliver Your Performance With Emotion.



D 440

D 550

D 660 S

D 770

D 880

D 880 S

C 900



AKG.SOUNDS.BETTER

## ”Let the audience feel your emotions.”

**The key to getting your emotions across to your audience is in your hand: the microphone.**

Knowing this, AKG left conventional wisdom behind and designed a new line of dynamic microphones that set a standard. Now the standard has once again been raised with the introduction of the first condenser EMOTION microphone, the C 900.

EMOTION Series microphones do not only look different but provide unique, patented solutions. What you get is unprecedented performance at an excellent price/performance ratio.



## ”I know just what I want.”

**For vocal or instrumental music, for moderators, lead, or backing vocalists,** only the best equipment should do on stage. EMOTION Series microphones meet the highest standards of quality. Unique, proprietary technologies such as the **”Varimotion™ diaphragm deep-drawing process”** or the **”Doubleflex™ shock mount”** for dramatically improved sonic performance make each EMOTION Series microphone an ideal tool on stage. Try the new EMOTION Series at your nearest AKG dealer and experience the new dimension of microphone performance made possible by the pioneering EMOTION technology.

# C 900

## The new performance vocal microphone for professional use.

The new C 900 is a professional condenser vocal microphone that will make your voice cut through the loudest mix - on any stage.

The C 900 features a frequency independent cardioid polar pattern that has not only been optimized for exceptionally high gain before feedback, but also for use with in-ear monitor systems.

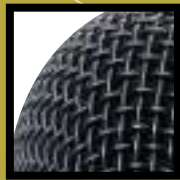

New, extremely durable Duraflex spring steel wire-mesh cap with integrated wind and pop screen.



XLR plug featuring 24 carat gold-plated pins. This connector is a worldwide professional standard.

## ”Discover Gold.”

The new C 900 is not only decorated with 24-carat gold on the outside, but there's more inside. The C 900 uses the same gold-sputtered transducer as many famous AKG studio microphones for exceptional performance.

A gold-plated XLR connector provides a perfect interface for optimum signal transmission unaffected by corrosion or other contact problems. Finally, a gold decorative ring on the microphone body symbolizes the unique quality of the C 900, the first condenser vocal microphone providing studio quality at the price of a dynamic mic.



Rubber shock mount ring and precisely matched brass weight for optimum suppression of handling and mechanical noise



US Pat. Nr. 4,790,021

24-carat gold-sputtered transducer case for optimum conductivity and resistance to corrosion and humidity.



The PB 1000 Presence Boost Adapter provides a 3-dB to 4-dB peak between 5 kHz and 13 kHz for better intelligibility and a crisp, clear sound.

## Patented electrode manufacturing technique.

The back electrode in the transducer consists of a metal foil stamped onto a special plastic backing\*. The surface of the electrode must be perfectly even, requiring an AKG exclusive patented process. The results are a highly accurate, flat frequency response and a precise, frequency independent cardioid pattern for high gain before feedback. The patented electrode support\*\* made of conductive plastic adds to the excellent acoustic performance of the microphone.

\*US Pat. No. 4,790,021 and Austrian Pat. No. 385.386

\*\*Austrian Pat. No. 392.182 and German Pat. No. 4.021.661



The C 900 package includes the microphone with its rugged die-cast metal body, a stand adapter, PB 1000 Presence Boost Adapter, and carrying case.

new!

EMOTION C 900

# D 880

## wireless

AKG makes wireless systems for all customer requirements and every budget, from the WMS 61 and WMS 81 professional multichannel systems to smaller systems such as the WMS 80, or the WMS 40, an entry level system that meets professional standards.

What they all have in common is that you will hear no difference between the wireless microphone systems and their hardwired counterparts. That's AKG quality!



15 selectable frequencies, Tone Code Squelch, pilot tone system for battery status data transmission, multichannel capability for simultaneous use of up to 24 channels.



15 selectable frequencies for interference-free operation, digital "Four Level Diversity" circuitry and SAW filters for interference-free reception, multichannel capability for simultaneous use of up to 19 channels, complete with 19" rack mount kit.



More than 35 hours of transmitter battery life, SAW filters for interference-free operation, complete set of displays for easy status monitoring, optional rack mount kit for easy installation in any 19" rack.

## The Varimotion™ Technology.

Varimotion technology refers to the patented process used to create the diaphragm. Using this technology, the thickness of the diaphragm can be varied during the manufacturing process resulting in a more accurate and natural reproduction of the sound.

Additionally, EMOTION Series microphones feature a neodymium (NdFeBr) magnet system to provide an

extremely powerful output signal. This will make your vocals cut through the loudest of rhythm sections.

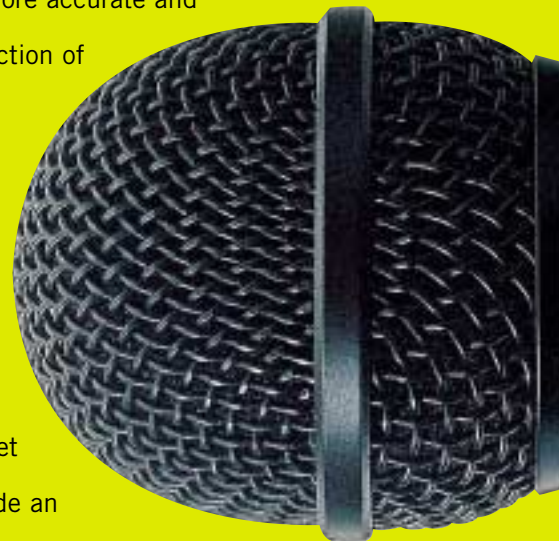

### VARIMOTION™ DEEP-DRAWN DIAPHRAGM

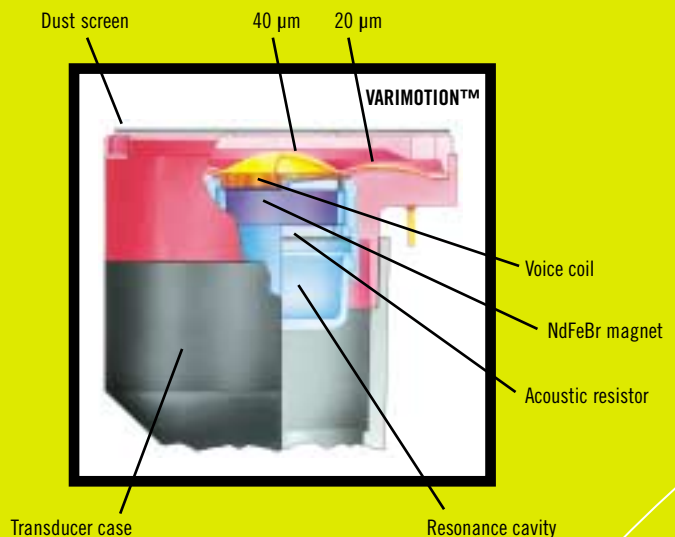

#### VARIMOTION™ (US Pat.No. 6,185,809, AT Pat.No. 403.751)

Innovative AKG deep-drawing technique. For the first time, diaphragms can be made whose thickness varies along their diameter. This reduces the need for expensive mechanical tuning resonators to a minimum.



New, extremely durable Duraflex spring steel wire-mesh cap with integrated wind and pop screen.



Silent on/off switch with clear status indication (D 880 S only).



XLR plug featuring 24 carat gold-plated pins. This connector is a worldwide professional standard.

# D 880 D 880 S

The Dynamic Vocal Microphone.



D 880

## The Doubleflex™ Shock Mount

This patented dual shock mount system developed by AKG suppresses all kinds of unwanted noise such as handling noise, a great advantage especially on stage. The microphone will "focus" on your voice rather than picking up unwanted noise.

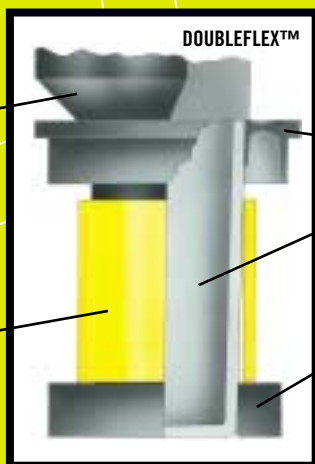

### DOUBLEFLEX™

The extremely efficient Doubleflex™ shock mount system comprises two separate shock absorbing suspension rings for the transducer. These work together to provide optimum suppression of handling and cable noise.

The D 880 and D 880 S are dynamic microphones for lead and backup vocals in tough onstage environments. An integrated wind and pop screen reduces breath noise, pop noise and sibilance extremely efficiently. The wind and pop screen can be easily removed from the wire-mesh cap and washed.

The D 880's frequency independent supercardioid pickup pattern provides high gain before feedback. The D 880 S is identical to the D 880 and features a silent on/off switch. The new Duraflex spring steel wire-mesh cap is unsusceptible to deep denting and thus affords optimum protection for the transducer capsule beneath it.



The D 880/D 880 S unidirectional dynamic microphone with rugged die-cast metal body comes complete with a stand adapter and carrying case. (D 880 S: special version with on/off switch.)

# D 770

# AKG.EMOTION

www.akg.com

EMOTION  
MICROPHONE  
SERIES

## The Multipurpose Microphone.

This multipurpose microphone with a classic style body slightly emphasizes the mid and high frequencies and is therefore an excellent choice for miking tom-toms, percussions, guitar amps, and wind instruments in a tough onstage environment.

Thanks to its good intelligibility, the D 770 is an excellent tool for miking lead and backup vocals as well.

The new Duraflex spring steel wire-mesh cap is resistant to deep denting and thus affords optimum protection for the transducer capsule beneath it.



BACKUP VOCALS



GUITAR AMP



SAXOPHONE



TOMS



### DOUBLEFLEX™-SHOCK MOUNT

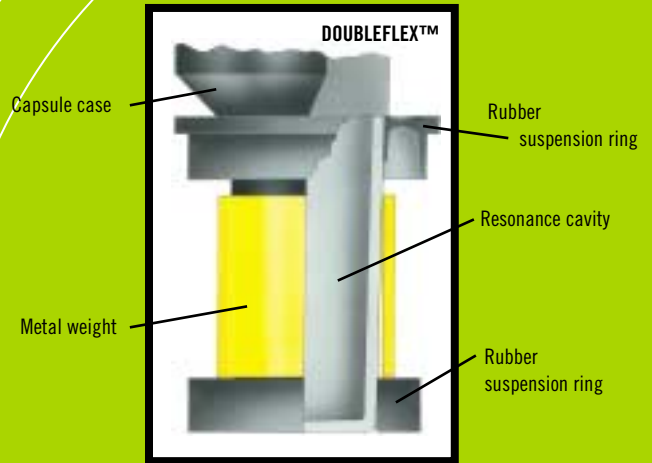

#### DOUBLEFLEX™

The extremely efficient Doubleflex™ shock mount system comprises two separate shock absorbing suspension rings for the transducer. These work together to provide optimum suppression of handling and cable noise.

### VARIMOTION™ DEEP-DRAWN DIAPHRAGM

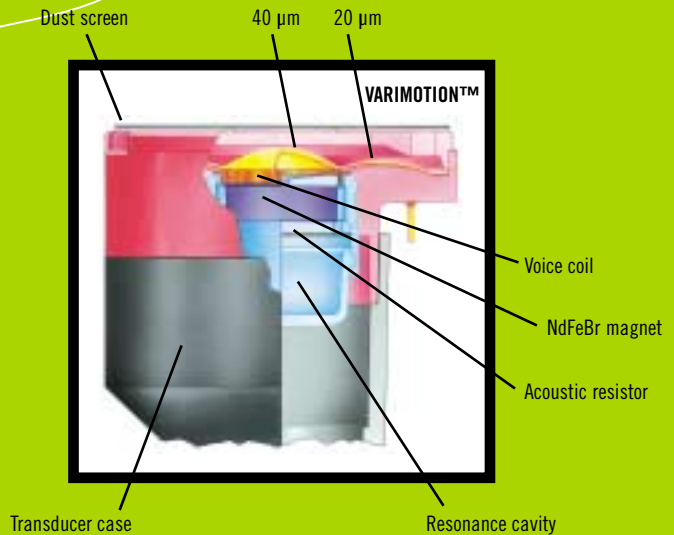

#### VARIMOTION™ (US Pat.No. 6,185,809, AT Pat.No. 403.751)

Innovative AKG deep-drawing technique. For the first time, diaphragms can be made whose thickness varies along their diameter. This reduces the need for expensive mechanical tuning resonators to a minimum.



New, extremely durable Duraflex spring steel wire-mesh cap with integrated wind and pop screen.



XLR plug featuring 24 carat gold-plated pins. This connector is a worldwide professional standard.



The D 770 unidirectional dynamic microphone with rugged die-cast metal body comes complete with a stand adapter and carrying case.

# D 660 S

## The All Out, All Around Vocal Microphone.

The D 660 S is a professional entry-level vocal microphone for all types of use. It has an unbeatable price/performance ratio. An extremely rugged protective basket ensures incredible durability and keeps the highly sensitive transducer out of harm's way. The wire-mesh cap is easy to remove for cleaning the internal wind-screen.



The D 660 S uses a dual shock mount to suppress of unwanted noise.



A protective basket provides the required ruggedness and protects the highly sensitive transducer. It is easy to remove and the internal windscreen is easy to clean.



The noiseless on/off switch clearly indicates microphone status.



The D 660 S unidirectional dynamic microphone with rugged die-cast metal body and integrated on/off switch comes complete with a stand adapter and carrying case.



# D 550

# AKG.EMOTION

www.akg.com

EMOTION  
MICROPHONE  
SERIES

## The Bass Instrument Microphone.

The D 550 bass instrument microphone featuring new, functional styling and a frequency response specifically tailored to miking up the bass drum, tuba, trombone, or bass amp.

Dynamic performance microphones with frequency responses specifically designed for instrument miking. The smooth frequency response of each microphone supports the sonic properties of specific instruments to ensure excellent performance in every situation.



BASS AMP



BASS DRUM



TROMBONE



SNARE

### VARIMOTION™ DEEP-DRAWN DIAPHRAGM

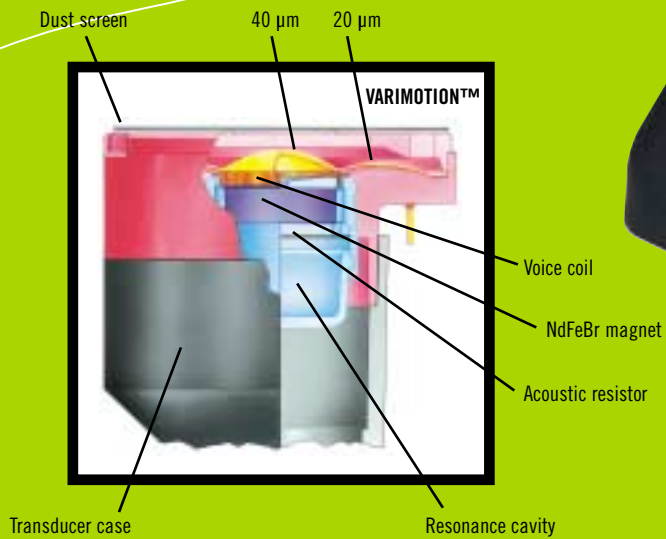

#### VARIMOTION™ (US Pat.No. 6,185,809, AT Pat.No. 403.751)

Innovative AKG deep-drawing technique. For the first time, diaphragms can be made whose thickness varies along their diameter. This reduces the need for expensive mechanical tuning resonators to a minimum.



The D 550 unidirectional dynamic microphone with rugged injection molded plastic body and integrated stand adapter comes complete with a carrying case and two StA 550 extension stubs for floor stand mounting.

”It gives me exactly the sound I want.”

# D 440

## The Instrument Microphone.

The D 440 is an instrument microphone featuring new, functional styling and a frequency response specifically tailored for miking tom-toms, percussion instruments, guitar amps, and wind instruments such as the trumpet or saxophone.



Swivel joint with integrated stand adapter.



XLR connector with stand adapter.

The D 440 unidirectional dynamic microphone with rugged injection molded plastic body and integrated stand adapter comes complete with a carrying case and an H 440 bracket for mounting the D 440 on a drum shell.



H 440 bracket for inconspicuous mounting of the D 440 on a drum shell.



GUITAR AMP



TOMS



TRUMPET



SAXOPHONE

## Grab a pack!

Customized packages for your individual application. Not all packages shown hereafter are available in all countries. Please check with your local AKG dealer.

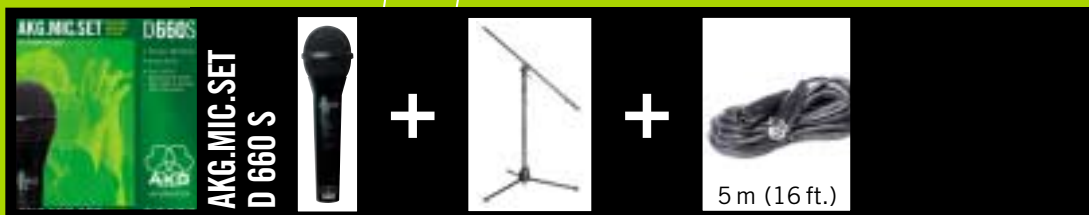

D 660 S

K&M 277

professional balanced microphone cable

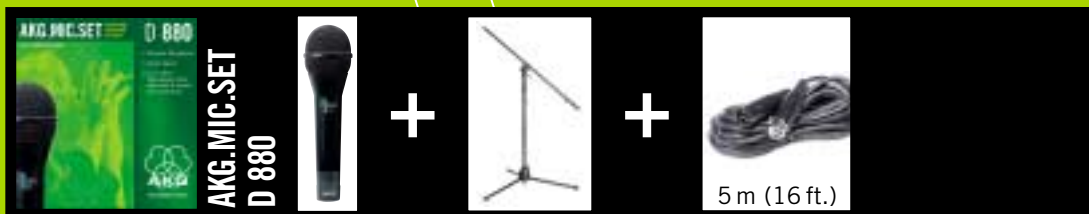

D 880

K&M 277

professional balanced microphone cable

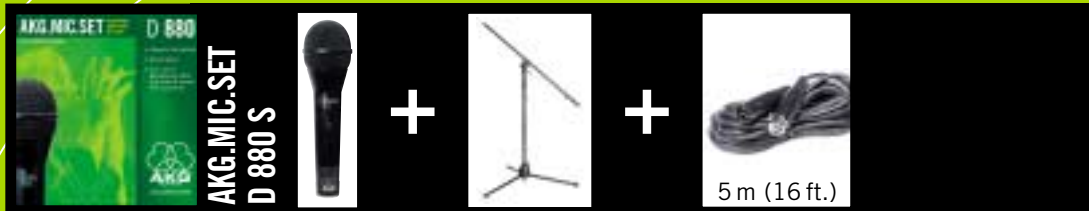

D 880 S

K&M 277

professional balanced microphone cable





rugged plastic carrying case

D 440

D 440

D 440

D 440

D 550



rugged plastic carrying case

D 440

D 440

D 550

D 770

D 770



rugged plastic carrying case

D 440

D 440

D 550

D 660 S

D 660 S

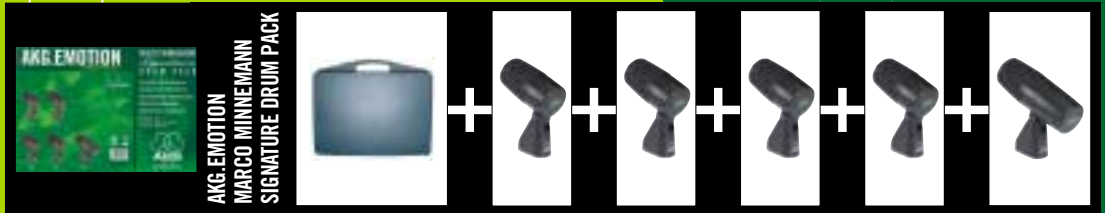

rugged plastic carrying case

D 440

D 440

D 440

D 440

D 550



www.akg.com

						
	<b>C 900</b>	<b>D 880 / D 880 S</b>	<b>D 770</b>	<b>D 660 S</b>	<b>D 550</b>	<b>D 440</b>
<b>Type</b>	Condenser microphone	Dynamic microphone	Dynamic microphone	Dynamic microphone	Dynamic microphone	Dynamic microphone
<b>Frequency range</b>	20–20,000 Hz	60–20,000 Hz at 1 cm: 20–20,000 Hz	60–20,000 Hz at 1 cm: 20–20,000 Hz	70–20,000 Hz	20–20,000 Hz	60–20,000 Hz
<b>Polar pattern</b>	Cardioid	Supercardioid	Cardioid	Hypercardioid	Cardioid	Cardioid
<b>Sensitivity at 1.000 Hz</b>	6 mV/Pa (-44 dBV re 1 V/Pa)	2.5 mV/Pa (-52 dBV re 1 V/Pa)	1.8 mV/Pa (-75 dBV re 1 µbar)	2.0 mV/Pa (-54 dBV re 1 V/Pa)	2.5 mV/Pa (-52 dBV re 1 V/Pa)	2.5 mV/Pa (-52 dBV re 1 V/Pa)
<b>Equivalent noise level</b>	17.5 dB (A) to DIN 45412	22 dB (A) to DIN 45412	22 dB-A (A) to DIN 45412	20 dB (A) to DIN 45412	18 dB (A) to DIN 45412	18 dB (A) to DIN 45412
<b>Max. SPL for 1 % (3 %) THD</b>	139/142 dB SPL	147 dB SPL (156 db SPL)	147 dB SPL (156 dB SPL)	140 dB SPL (150 dB SPL)	147 dB SPL (156 dB SPL)	147 dB SPL (156 dB SPL)
<b>Electrical impedance</b>	≤ 200 Ω	≤ 600 Ω	≤ 600 Ω	≤ 500 Ω	≤ 600 Ω	≤ 600 Ω
<b>Recommended load impedance</b>	≥ 2.000 Ω	≥ 2,000 Ω	≥ 2,000 Ω	≥ 1,200 Ω	≥ 2,000 Ω	≥ 2,000 Ω
<b>Connector</b>	3-pin male XLR	3-pin male XLR	3-pin male XLR	3-pin male XLR	3-pin male XLR	3-pin male XLR
<b>Finish</b>	Matte black enamel	Matte black enamel	Matte black enamel	Matte black enamel	Matte black enamel	Matte black enamel
<b>Size</b>	Length: 180 mm (7.1 in.) max Ø: 50 mm (2 in.)	Length: 181 mm (7.13 in.); Ø: 50 mm (1.97 in.)	Length: 181 mm (7.13 in.); Ø: 50 mm (1.97 in.)	Length: 181 mm (7.13 in.); Ø: 50 mm (1.97 in.)	Length : 121 mm (4.76 in.); Height : 104 mm 7.09 in.); Ø: 46 mm (1.81 in.)	Length : 85 mm (3.35 in.); Height : 104 mm 7.09 in.); Ø: 46 mm (1.81 in.)
<b>Net/Shipping weight</b>	295/650 g (10.4 oz./1.4 lb.)	290/600 g (10.4 oz./1.3 lb.)	290/600 g (10.4 oz./1.3 lb.)	240/420 g (8.5 oz./0.9 lb.)	203/563 g (7.2 oz./1.2 lb.)	148/438 g (5.2 oz./2.2 lb.)
<b>Standard accessories</b>	SA 41/1, PB 1000 Presence Boost Adapter	SA 44, W 880 windscreen	SA 44	SA 44	Table stand, extension tubes	H 440
<b>Optional accessories</b>	Table stands: ST 1, ST 12, ST 45, ST 305 Floor stands: 102 A, ST 200 Microphone cables: MK 9/10 Windscreens: W 23, W 880 Stand adapters: SA 41/1, SA 44					

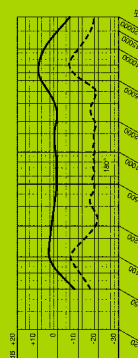
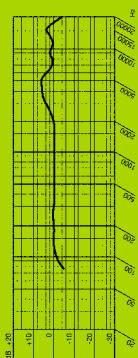
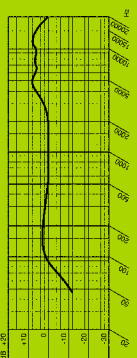
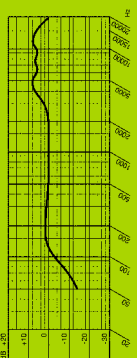
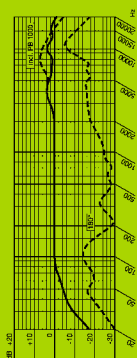

Photos: Ross Halfin, Julian Barton, AKG

#### AKG Acoustics GmbH

Lemböckgasse 21–25, P.O.B. 158, A-1230 Vienna/AUSTRIA,  
Tel: (43 1) 86 654-0\*, Fax: (43 1) 86 654-516, <http://www.akg.com>, e-mail: [sales@akg.com](mailto:sales@akg.com)

#### AKG Acoustics GmbH

Bodenseestraße 228, D-81243 München/GERMANY, Tel: (089) 87 16-0,  
Fax: (089) 87 16-200, <http://www.akg-acoustics.de>, e-mail: [info@akg-acoustics.de](mailto:info@akg-acoustics.de)

#### AKG ACOUSTICS, U.S.

914 Airpark Center Drive, Nashville, TN 37217, U.S.A., Tel: (615) 620-3800,  
Fax: (615) 620-3875, <http://www.akgusa.com>, e-mail: [akgusa@harman.com](mailto:akgusa@harman.com)

© A Harman International Company

For detailed information on Emotion-Series and other AKG products  
contact your distributor or visit our website: [www.akg.com](http://www.akg.com). Specifications subject to change without notice.



AKG.SOUNDS.BETTER