



H A Harman International Company

WMS 61

VHF Wireless Microphone System

Description

The WMS 61 wireless microphone system comprises a bodypack transmitter or handheld microphone, a receiver and optional accessories. The bodypack and handheld transmitters have the same transmission characteristics, with a maximum radiated power of 10 milliwatts. Through signal companding (compression and expansion), a dynamic range greater than 100 dB is attained at the receiver's output. Audio bandwidth extends from 50 Hz to 20 kHz. Through diversity reception, the performance of the system is uniform over a wide range in typical performance spaces, extending up to distances of 330 feet (100 meters).

Individual handheld microphone and bodypack transmitters are factory matched to a given receiver. Fifteen channels are available in each of seven VHF bands that occupy the following range: 176 - 216 MHz. Because of some channel overlap, and the recommendation that adjacent sub-channels not be used in a given installation, the user may expect up to 13 usable channels in a given installation.

The Model PT 61 bodypack is powered by 2 AA batteries, and normal battery life of 10 hours can be expected from alkaline 1.5 volt cells. The PT61 accepts both microphone and instrument level input signals, and input sensitivity can be adjusted for optimum performance. The antenna is a quarter-wavelength wire, affording easy concealment and comfortable wearing.

The Model HT 61 handheld transmitter uses modular microphone capsules. Three of AKG's most popular handheld vocal microphone head units are available for the handheld transmitter. The microphones are the models D 880 WL/1, D 3800 WL/1 and C 535 WL/1. The handheld transmitter has the following controls: power on/off, microphone mute, input sensitivity control, and selection of the desired transmitting frequency. Powering of the handheld transmitter is the same as for the bodypack. Battery life of 10 hours can be expected.

The SR 61 receiving unit is one standard rack unit high and one-half rack unit wide. Thus, two receiving units can be placed side by side. Each SR 61 comes from the factory with the chosen VHF bandwidth containing a set of 15 preset operating frequencies. The SR 61 is a diversity receiver providing optimum signal reception.

Controls on the SR 61 include: power switch, carrier frequency selection, and output level control. Indicators on the unit include: mute, audio overload, RF, diversity LEDs, and transmitter battery status. Squelch is automatic and provided by the TCSQ™ circuit. Each SR 61 can accommodate a pair of antennas, however, when a number of receivers are used in a single installation, a master antenna pair (with booster) can be used to feed to all receivers.

A wide range of accessories is provided for operational flexibility and ease of installation. Figures 3, 4 and 5 show how multiple receivers, power supplies and power splitters can be combined for the maximum number of wireless microphones.



Features

- 15 selectable frequencies
- Factory matched and optimized transmitter/receiver frequency sets
- Diversity reception
- Dynamic range >100 dB
- Simple, foolproof setup procedure
- Both bodypack and handheld microphone transmitters available
- 7 VHF frequency sets available

Specifications

PT 61 bodypack transmitter:

Audio bandwidth:	50 Hz to 20 kHz
Modulation method:	FM
Radiated RF power:	10 mW
Frequency stability:	±10 ppm
Antenna:	Flexible, quarter-wave wire
Rated deviation:	±30 kHz
Signal-to-noise ratio:	Typical 50 dB (A weighted)
Input impedance:	220 k ohms, 600 pF
Audio input:	Mini 3-pin XLR; 1400 mV for rated deviation at 1 kHz
Phantom powering:	Pin 3: 6 V/6k8 ohms
Current consumption:	170 mA/2.4 V
Power requirement:	2 AA 1.5V batteries
Battery life:	>10 hours
Dimensions:	3.62 x 2.56 x 0.79 in. (92 x 65 x 20 mm)
Net weight:	3.04 oz. (76 g) without batteries

HT 61 handheld transmitter:

Type, bandwidth and polar pattern:	See individual microphone specification sheets
Modulation type:	FM
RF radiated power:	10 mW
Rated deviation:	±30 kHz
Signal-to-noise ratio:	Typical 50 dB (A-weighted)
Current consumption:	<150 mA/2.4 V
Power requirement:	2 AA size 1.5V batteries
Battery life:	>12 hours
Dimensions:	1.4 x 9.4 in. (36 mm dia. x 240 mm)

Net weight: 9.8 oz. (245 g)

SR 61 receiver:

Receiver type:	Diversity
Antenna inputs:	2 x 50-ohm BNC sockets
Modulation type:	FM
Input sensitivity:	Typical -95 dBm
Squelch threshold:	Automatic, using pilot tone (32.678 kHz)
Audio bandwidth:	50 to 20 kHz
THD at 1 kHz:	<0.4% at rated deviation
Signal-to-noise	Typical 100 dB (A-weighted)
Audio output:	Balanced XLR-M, mic/line level switchable, typical 30 dB unbalanced: 1.4" jack: 0 dBm XLR: 6 dBm
Current consumption:	220 mA typical
Power requirement:	11 to 15 V dc or ac from external power supply
Dimensions:	8.27 x 6.7 x 1.65 in. (210 x 170 x 42 mm)
Net weight:	18.8 oz. (470 g)

Optional Accessories:

PS 61:	Active, wideband antenna splitter for connecting up to 4 SR61 units or 3 SR61 units and one additional PS.
RA 61:	External receiver antenna with integrated booster, powered via cable from the PS61 antenna splitter.
PSU 10:	Central power supply unit for support of up to 10 SR61 and up to 3 PS 61 units.
SRA-1:	External directional antenna
Color code set:	Part #2455Z0051 For easy channel recognition
Hard Case CH 60:	For carrying a single complete system
UAS 1:	Universal antenna splitter for 2 receivers
UAM 1:	Universal antenna mount for moving the antennas for 1 receiver to the front of the rack.

Architects and Engineers Specifications

The wireless microphone system shall operate selectively over the VHF frequency range from 176 - 216 MHz, providing at least 15 usable channels with transmitter power not exceeding 10 milliwatts. Both handheld and bodypack type transmitters shall be provided. The transmitters shall operate with a companding system that is complemented by the receiver, providing an A-weighted system dynamic range in excess of 100 dB. The transmitters shall provide the following switchable functions: input sensitivity, power on/off, and microphone mute.

Handheld transmitters shall have a maximum diameter of 1.4 in. and a length no greater than 9.4 in.

The receiver shall operate on the diversity principle, and that action shall be inaudible as such. Total harmonic distortion at 1 kHz for rated deviation shall be no greater than 0.4%. The receiver shall incorporate a coded squelch circuit and shall provide automatic squelch adjustment for optimum system operation. An output level adjustment shall be provided, and there shall be both balanced XLR-M output and unbalanced 0.25 in. (6.5 mm) jack. The wireless microphone system shall be the AKG Acoustics Model WMS 61.

Graphical Data

Figure 3

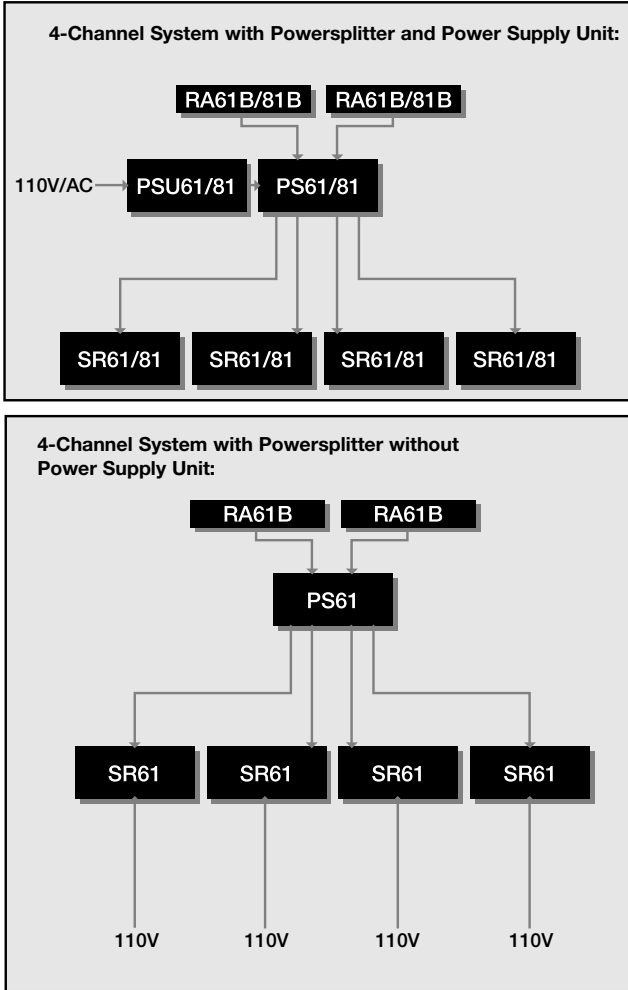
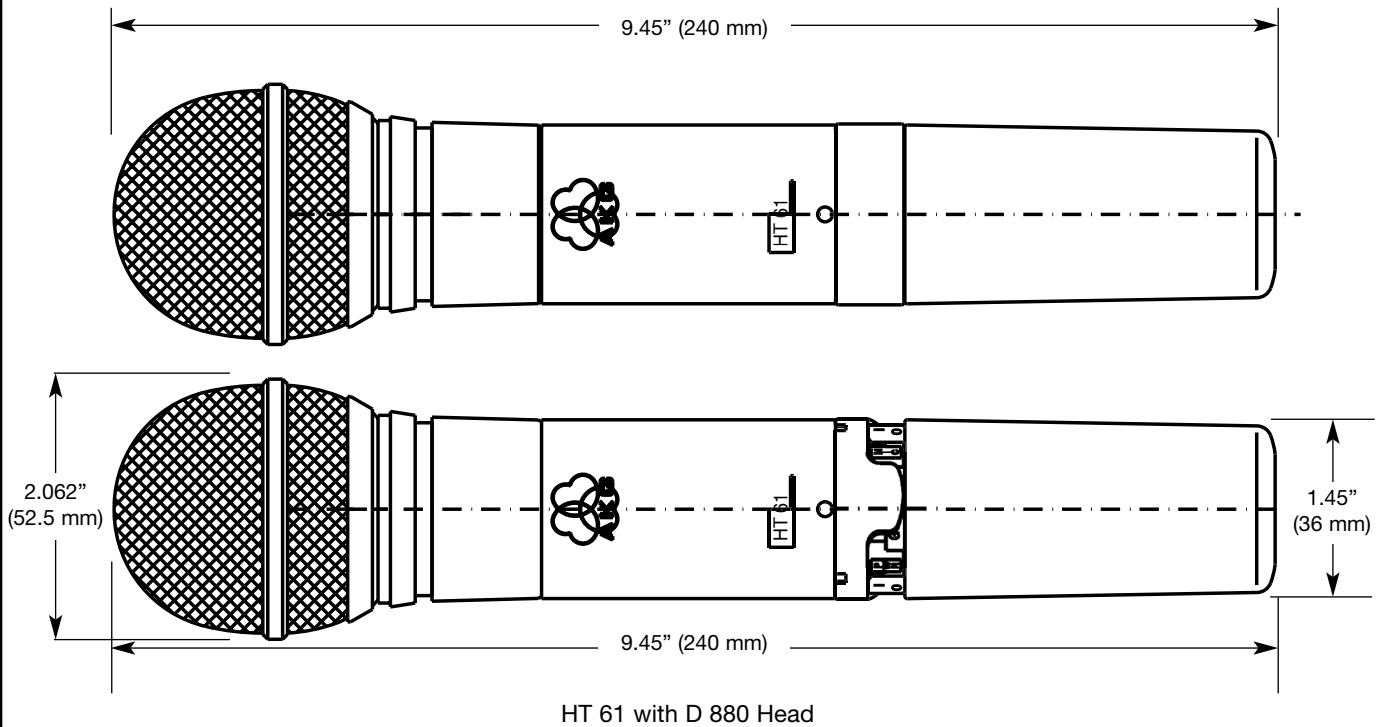
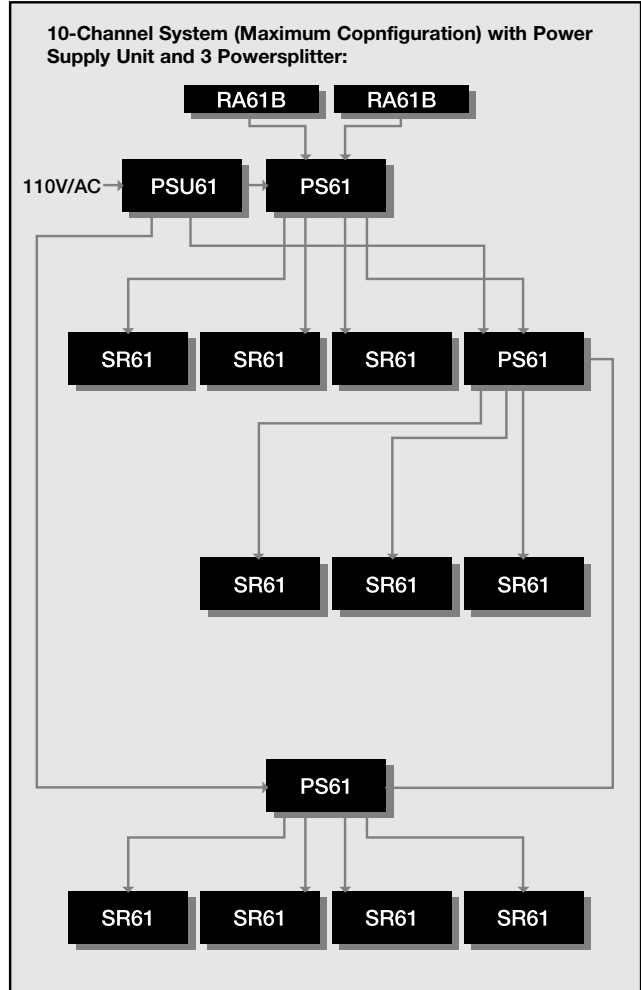
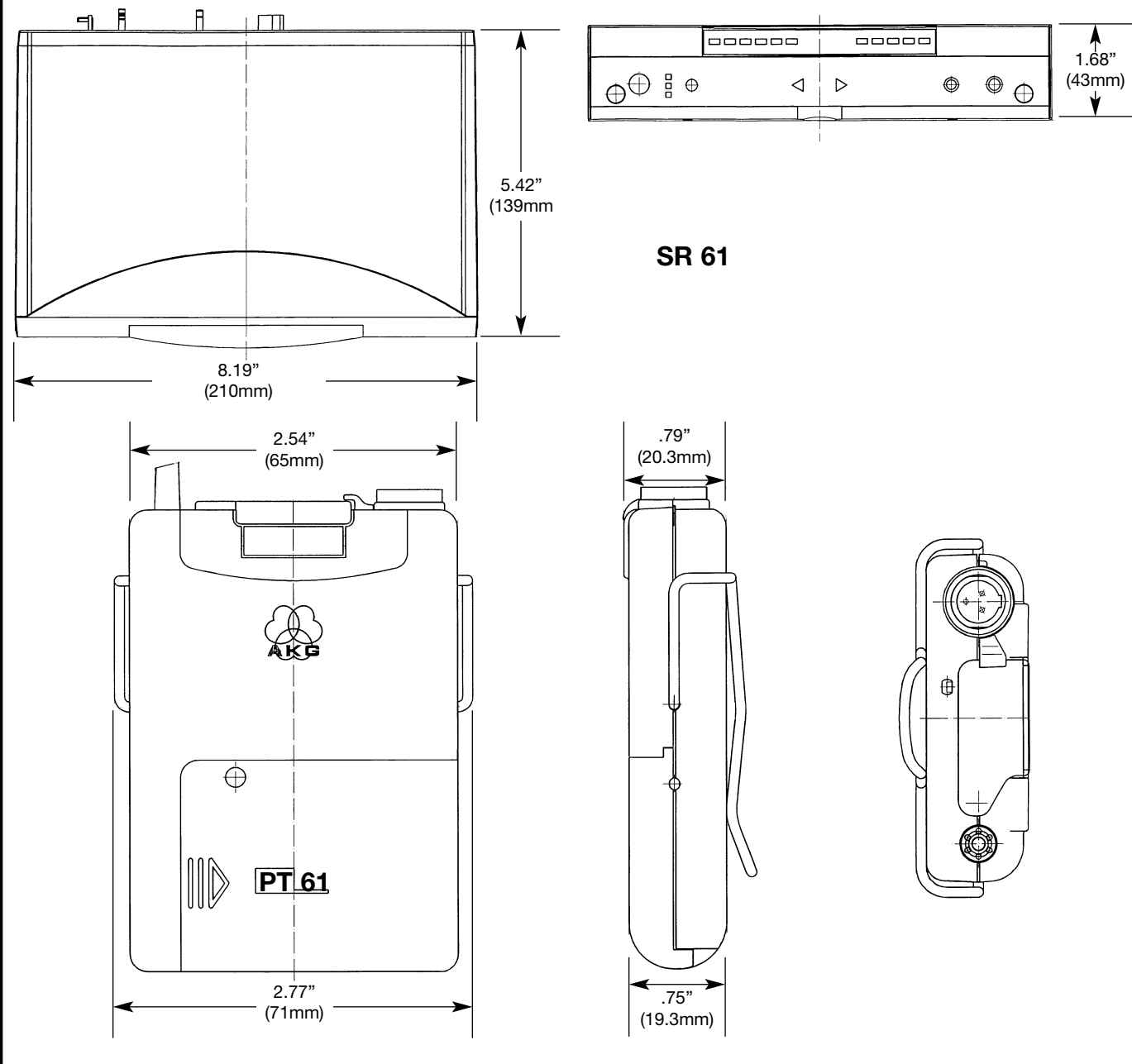

Figure 5



Graphical Data



AKG is constantly improving and modifying its products, therefore, specifications are subject to change without notice.

Limited Warranty

Valid only in the United States. AKG Acoustics warrants AKG products against defects in material or workmanship for a period of two years from the date of original purchase for use, and agrees to repair or, at our option, replace any defective unit without charge for either parts or labor. Important: This warranty does not cover damage resulting from accident, misuse or abuse, lack of reasonable care, the affixing of any attachment not provided with the product, loss of parts or connecting the product to any but the specified receptacles. This warranty is void unless service or repairs are performed by an authorized service center. No responsibility is assumed for any special, incidental

or consequential damages. However, the limitation of any right or remedy shall not be effective where such is prohibited or restricted by law. Simply take or ship your AKG product prepaid to our service department. Be sure to include your sales slip as proof of purchase date. (We will not repair transit damage under the no-charge terms of this warranty.) Note: No other warranty, written or oral is authorized by AKG Acoustics, Inc. This warranty gives you specific legal rights, and you may also have other rights which vary from state to state. Some states do not allow the exclusion or limitation of incidental or consequential damages or limitation on how long an implied warranty lasts, so the above exclusions and limitation may not apply to you.

Microphones · Headphones · Wireless Microphones · Wireless Headphones · Headsets · Electroacoustical Components



H A Harman International Company

AKG Acoustics GmbH
Lemböckgasse 21-25, P.O.B. 158, A-1230
Vienna/AUSTRIA
Tel: (43 1) 86 654-0*, Fax: (43 1) 86 654-516
Internet: <http://www.akg.com>

AKG Acoustics; A Division of Harman Pro Germany
Bodenseestraße 228, D-81243 München/GERMANY
Tel: (089) 87 16-0, Fax: (089) 87 16-200

Arbiter Pro Audio
Wilberforce Road, London NW9 6AX/ENGLAND
Tel: (0181) 202 1199, Fax: (0181) 202 7076

AKG ACOUSTICS, U.S.
914 Airpark Center Drive
Nashville, TN 37217, U.S.A.
Tel: (615) 620-3800, Fax: (615) 620-3875

Studer Japan Ltd.
2-43-7, Uehara, Shibuya-ku, Tokyo 151-0064/JAPAN
Tel: (813) 3465-2211, Fax: (813) 3465-2214

Erikson Pro Audio
620 McCaffrey, St-Laurent, Quebec, H4T 1N1, CANADA
Tel: (514) 738-3000, Fax: (514) 737-5069
Internet: www.jam-ind.com/eriksonpro